



EFRA 1:10 Off-Road Chairman  
Paul Worsley  
23, Prince Rupert Road  
Stourport-on-Severn  
Worcestershire, DY13 0AS. UK.

Mobile: +44 (0)7946 750010  
Home: +44 (0)1299 871137  
E-mail: paul.worsley@virgin.net

## EUROPEAN FEDERATION OF RADIO OPERATED MODEL AUTOMOBILES

01 April. 2014

### 2014 -- 1/10<sup>TH</sup>. OFF-ROAD EVENTS, SANCTIONED BY EFRA. CLARIFICATION OF WHEEL SIZE REQUIREMENTS.

#### 1/10th. OFF-ROAD BUGGY WHEELS :

There have been recent queries regarding the size of wheels allowed at EFRA 1/10<sup>th</sup>. Off-Road Sanctioned events.

**TO CLARIFY:-** The **MAXIMUM** bead mounting dia. of wheels allowed at EFRA 1/10<sup>th</sup>. Off-Road Sanctioned events is **55.88 mm. (2.2 Inches).**

The Bead mounting dia. Is measured at the point where the internal tyre bead locates into the wheel.

The above dimension complies with IFMAR rules, which EFRA always strive to comply with.

**The vast majority of OEM wheels supplied with car kits comply with the above dimension, and have done for many years.**

*Rationale:* For the past 25 years, all manufacturers have complied with IFMAR (and ROAR) rules and have produced wheels with a tyre bead mounting diameter of 55.88 mm. (2.2 inches). The EFRA 1/10<sup>th</sup>. Off-Road Section have not previously found it necessary to state a diameter dimension in the rules as all manufacturers have made wheels to comply with the IFMAR 55.88 mm. maximum.

In Oct 2013, it was found that a wheel/tyre manufacturer in the USA started producing wheels that are larger than 55.88 mm. The information came too late to clarify dimensions in our rules at the AGM. It will be done at the next AGM.

These oversize wheels are not allowed at EFRA Sanctioned events.

The drawing below shows the wheel dimensions required by IFMAR rules. EFRA will use the same dimensions at sanctioned events.

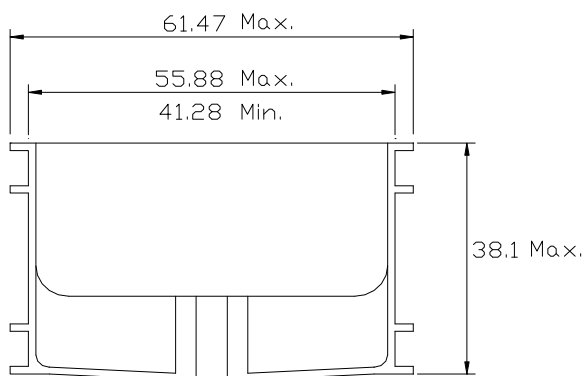

I hope this helps to clarify the EFRA stance on this issue.

Paul Worsley. (EFRA Section Chairman - 1/10th. Off-Road).

01.04.14